

din20:

Din rail isolator & transmitter

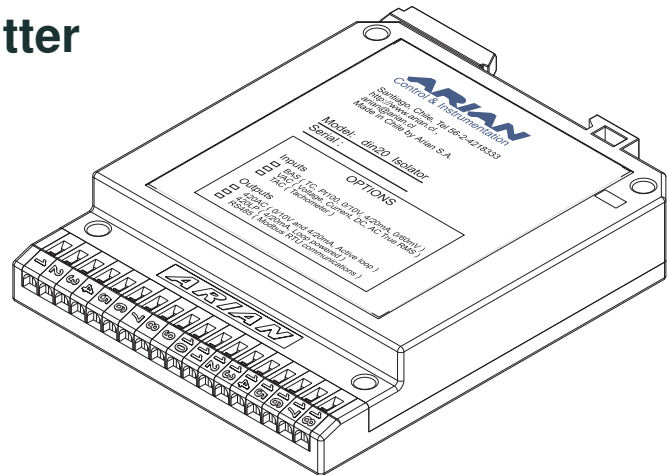

din20-bas: Thermocouples, Pt100, 4..20ma, 0..10V process inputs.

din20-vac: True RMS AC/DC Volt, Amper input.

din20-tac: Tachometer 0.01 Hz.. 50KHz pulse input.

Isolated 4/20ma and 0/10V outputs.

RS485 modbus RTU serial communications.

4 alarm set points associated with 2 output solid state relays.

General description

The din20 din rail isolators are based on Arian id20 digital panel indicators, having the same functionalities except for not having a display and enhanced isolation characteristics. Composed by 3 sub-models (din20-bas, din20-vac, din20-tac) they cover a broad range of input types.

Isolation

Complete galvanical isolation between: power supply, input, analog output, solid state relays and RS485 communications.

Inputs

The **din20-bas** includes thermocouples, Pt100, 4...20mA, 0...10V and 0...50mV process inputs.

The **din20-vac** is a AC true RMS volt and amper input instrument, (also bipolar DC) with several scales. May be used with shunts, current transformers or direct measurement of AC/DC voltages up to 600V.

The **din20-tac** is a tachometer or rate meter, only accepts pulse inputs e.g.. NPN, PNP and Mechanical Switch. Frequency measurement is done counting the input pulses and simultaneously measuring the time among them. This method allows precise and quick readings especially at low frequencies where the measurement is obtained mainly from the period (time) among pulses. Simplifies input programming not having to define "time windows" on which the count is carried out.

Alarms

Possess two output solid state relays, each one corresponds to 2 programmable alarms (high and low). Alarms can be absolute or relative to a general set point.

Analog output

Isolated analog outputs 0/10Volt, 4/20mA active or loop powered.

Programming

Set up and configuration is done by the Arian RPS software running on a PC. Computer connection is made to the RS485 port (using the ISO485 interface) or to the internal connector with the RPS interface.

Since functionalities are exactly equivalent with the id20 panel meters, detailed configuration is found on the id20 user manual.

TECHNICAL SPECIFICATIONS

INPUTS

din20-bas Resolution 16 bit a/d, CMRR 100 dB min., 400 VAC. Min.
Input break protection TC with preset action.
Thermocouples (100 ohm max.): Centigrade Degrees or Fahrenheit
J (-60, 760) °C
k (-100, 1372) °C.
T (-86, 400) °C.
R -1 mV, 1767 °C.
S -1 mV, 1764 °C.
B -1 mV, 1815 °C.
N (-139, 1298) °C.
E (-176, 750) °C.
Platinel (0, 1394) °C.
C (0, 2314) °C.
D (0, 2314) °C.
G (0, 2313) °C.
PT100 (-136, 450) °C DIN43760, alpha=0.0385
4...20 mA, 0...20 mA, 0...5 V, 1..5 V, 0..10 V, 0..50 mV, scalable for engineering units.

din20-vac: Resolution: 18 bit a/d, CMRR 100 dB min., 400 VAC. Min.
Dc: Bipolar simetrical input (positive/negative voltages/ currents)
Ac: True RMS.
Scales: 5 Amperes, 60mV, 2V, 6V, 20V, 60V, 200V, 600V

din20-tac: Pulse inputs: NPN, PNP, Mechanical switch, TTL, High voltage (500 V).
Provides feeding for input sensor, +5, -7.5 Vdc, 30mA max.
Frequency range 0.01Hz ... 50KHz

ALARM RELAYS Two solid state bipolar (for DC or AC use) relays outputs for alarms 400 VDC max and 200mA max.
This must be used with external larger power relays unless are conected to low power loads such as PLC or DCS inputs.
Normally open or normally close software configured.
Independent alarm outputs, each one with high and/or low alarm, with absolute or relative set point.

RS485 Modbus RTU protocol serial communications, half duplex (RS485 not RS422)
Opto isolated up to 5kV

ANALOG OUT

Loop powered: 4... 20 mA, loop powered,
Voltage drop 4.5V max., Operating voltage 30V max.
Opto isolated (5kV).

Active loop: 0-10V and 4..20mA Active loops, driving up to 13 volts onto loads (600 ohms max. load)
Opto isolated (5kV).

POWER SUPPLY: Low noise switching power supply.
5kV min. isolation from analog input.
20Vdc... 28Vdc, 3 W max.

CONSTRUCTION: Reinforced polyester
Total Dimension: 121 x 98 x 23 mm.
Weight: 200 grams.
Operation temperature: 0 ... 50 °C.

PROGRAMMING

Set up configuration is done with the RPS (remote programming) software provided on <http://www.arian.cl/downloads/arianrps.zip> and running on windows PC.

Connection can be done from the RS485 lines using the ISO485 interface to the PC RS232 comm port . Also may be done using the RPS interface cable plugged to the internal connector, taking care of the “UP” direction for the connector, as seen on the figure.

Remove the four top cover screws for accessing the RPS connector and other internal jumpers needed for setting the input and output type.

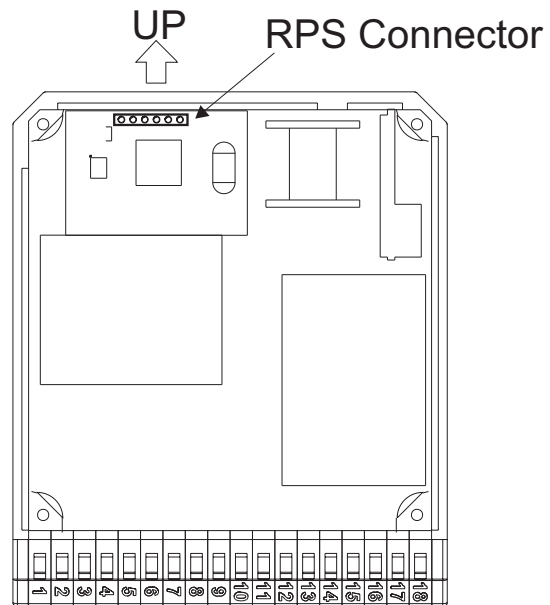

The RPS software will recognize the device and load the proper driver for reading and writing configuration parameters.

Since the din20 is functionally equivalent to the ind20 panel meters, you may refer to the id20 user manual for further references.

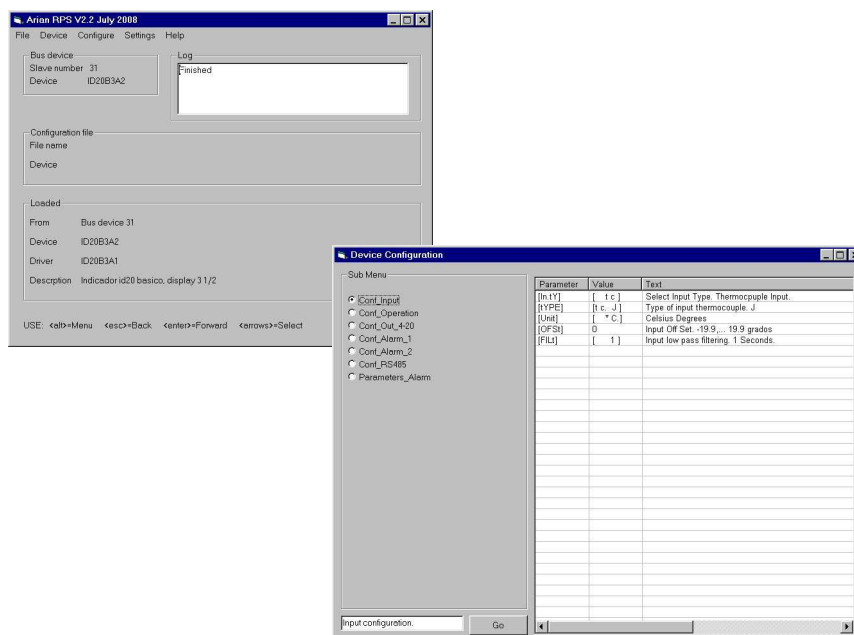

Analog output and solid state relay outputs

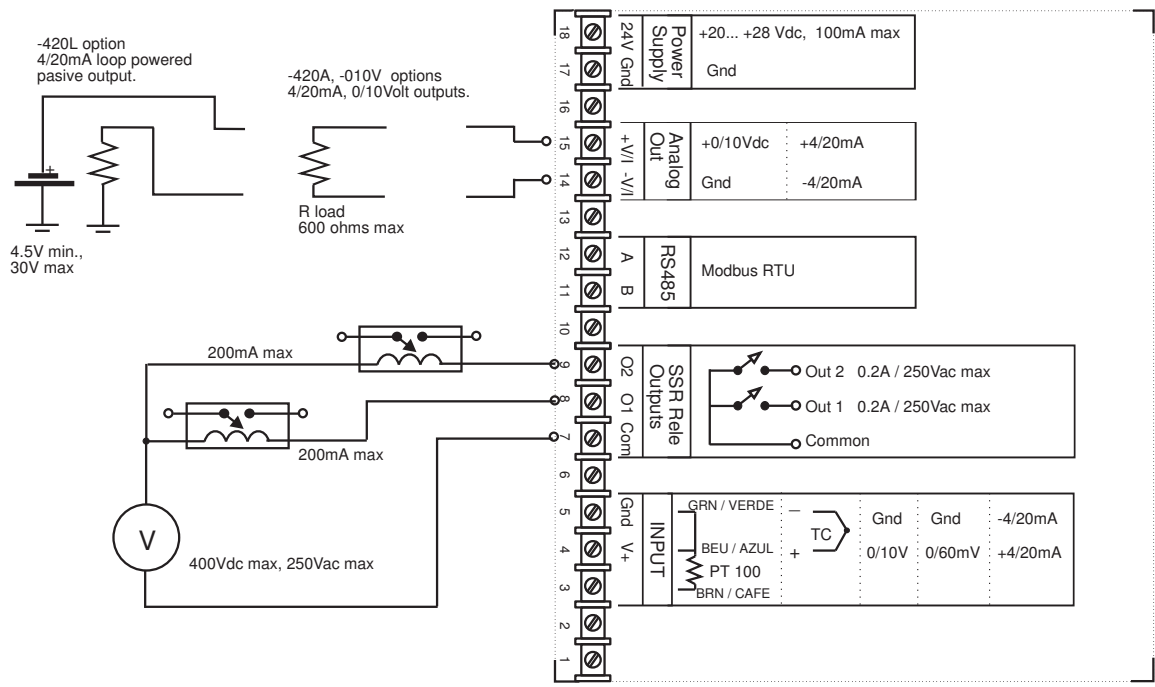

fig-din20-1

Input connections

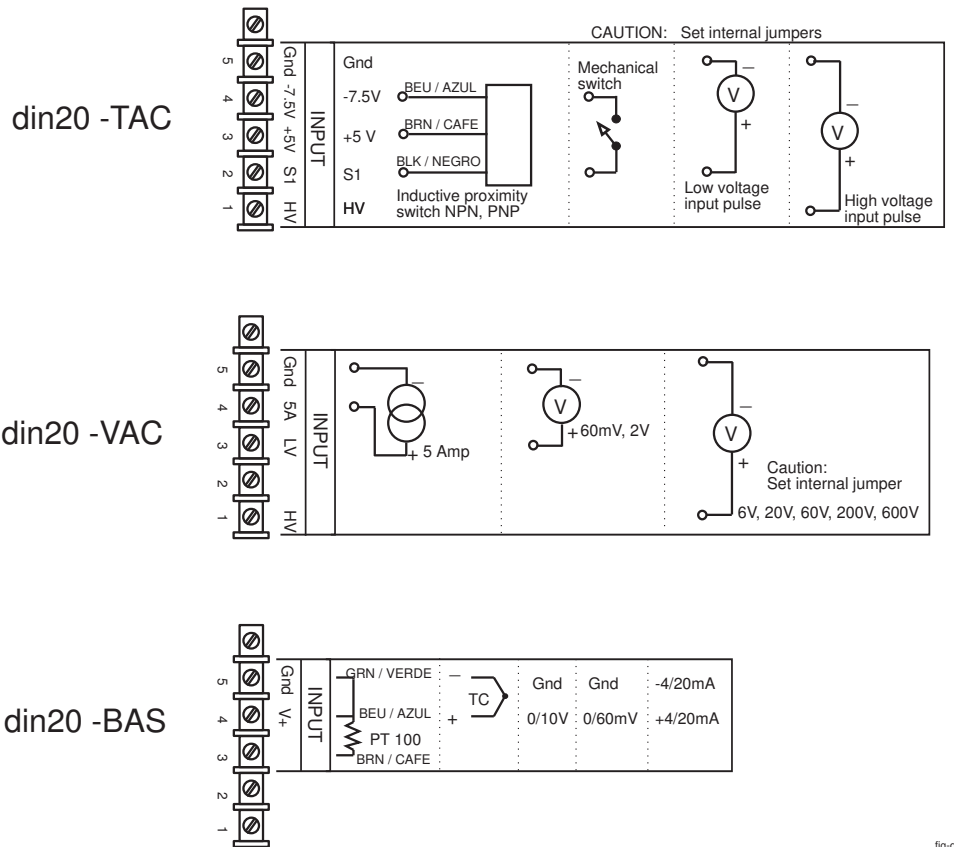
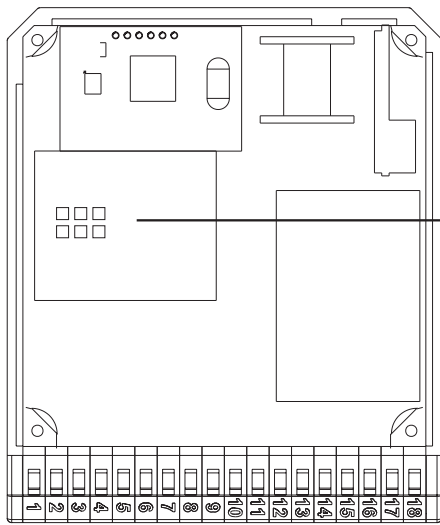

fig-din20-2

Input configuration jumpers



din20-BAS

	Thermocouples, Pt-100, 0-50mV
	4-20mA, 0-20mA
	0-10V, 0-5V, 1-5V

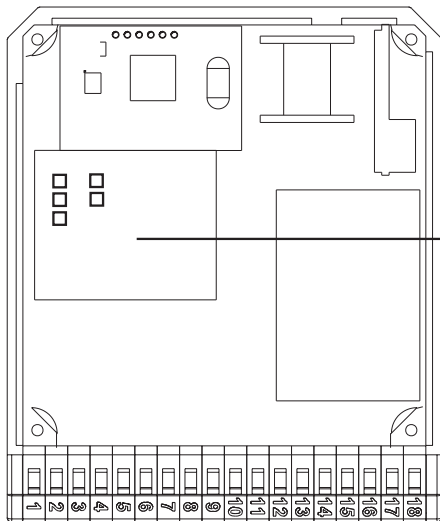

din20-TAC

NPN 	PNP 	TTL Low Voltage
Mechanical Switch 		

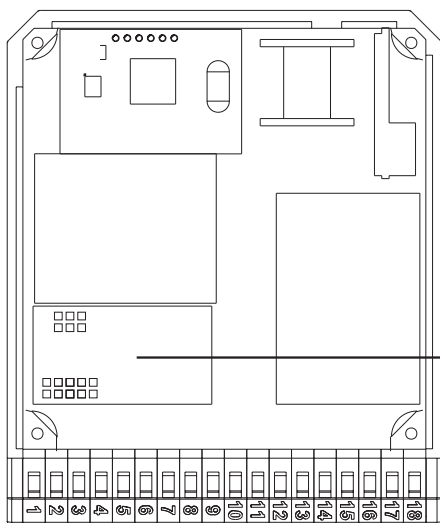

din20-VAC

5 Amp. 	60mV 	2V 	6V
20V 	60V 	200V 	600V

din20_03

PART CODES:

din20-

-
- BAS : thermocouples, pt100, 0-10V, 4-20ma, ...
 - TAC :rate meter
 - VAC :amperimeter, voltmeter DC and AC true RMS.
-

Optional

- 420L 4..20mA pasive loop analog output.
- 420A 4..20mA active, analog output.
- 010V 0..10Vdc analog output.
- RS485 modbus RTU serial communications

Example: din20-BAS-420A-RS485

MORE INFORMATION:

ARIAN S. A.

El Comendador 2340, Providencia
Santiago, Chile
Fono/Fax 56-2-4218333
arian@arian.cl
www.arian.cl